

## BH4C Solarium Installation Instructions



**Please note:** This equipment must be installed in accordance with the current edition of the IEE wiring regulations BS7671 18<sup>th</sup> edition by suitably qualified personnel. These regulations contain important requirements regarding the safety of electrical equipment. For International Standards refer to IEC 60364.

**Included:**

- 4x 1.5kW specialist infrared heaters & mounting brackets
- 1x 6kW push-button timer
- 1x 6kW variable energy-saving controller

### 1.0 Overview

The **BaskZone® BH4C** 6kW solarium is designed to deliver a broad infrared heat distribution by the positioning of the heaters above and to both sides of the horse. Its operation is fully controllable through the variable heat controller, while a push-button timer ensures the system is not inadvertently left on. The IPX5-rated infrared heaters are splashproof and can be wiped clean. Regular removal of any dust on the reflectors is recommended to ensure performance and maintain maximum heat output.

- Instant heat output – no warm-up required
- Fully controllable using supplied controllers
- Tilt-adjustable mounting brackets
- Full wrap-around heat
- Silent operation
- Horse-safe

**Figure 1 – BH4C Solarium layout:**

A key principle of the BaskZone® BH4C Solarium is that the heaters are mounted at a safe distance from the horse.

This allows access to the horse for treatment and handling, and the horse is free to move around within the infrared zone.

In open areas, cross tying or ring tying may be appropriate.

The infrared elements are available as replacement parts from BaskZone®.



## 2.0 Installation

### 2.1 Connecting the heaters

For the BaskZone® BH4C solarium, 2 heaters are joined together and mounted above and to both sides of the horse. There are linking plates supplied which connect the two heaters together ready for wall or ceiling mounting.



### 2.2 Siting the Ascot infrared Heaters

The BH4C heaters should be mounted on a sound, vibration-free wall or ceiling using the brackets supplied.

**Figure 2 - Siting the BH4C infrared Heaters:**



The BH4C Solarium comprises of two Infrared heaters of which both should be within 3° of horizontal. The heaters must be mounted above and to the sides of the horses, aiming down at approximately 45° as shown in Figure 2. The heaters produce a broad and even distribution of infrared radiation at 1.8 to 2.5 meters from the face of the heaters. The heaters emit infrared heat in a V-shape. As a result, the closer the heater is to the horse, the more warmth the horse will feel. Conversely, increasing the distance between the heater and the horse spreads the heat over a larger area, but the intensity of warmth felt by the horse decreases.

**Figure 4 - Recommended clearances:**

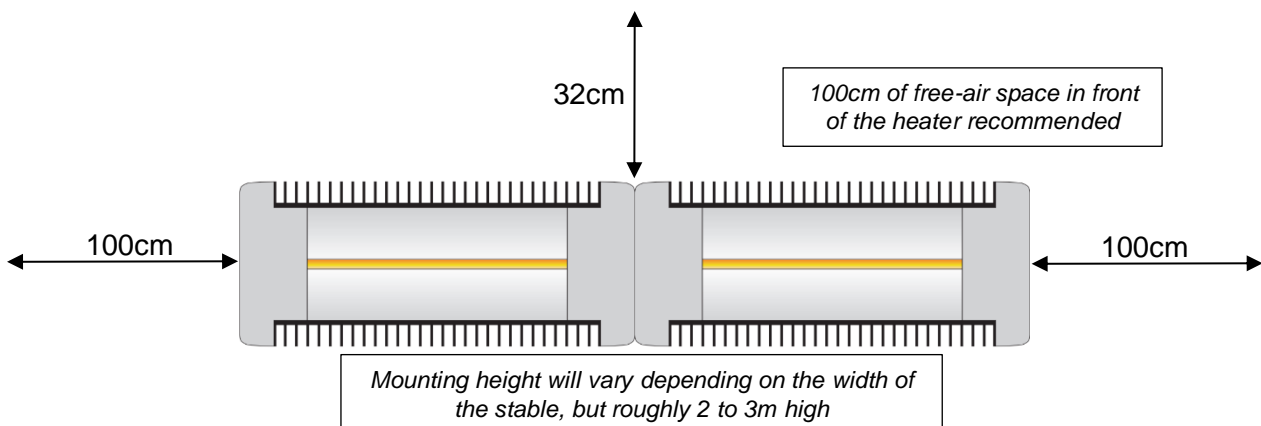

### 2.3 Mounting brackets

Mounting brackets are provided for each heater. They should be securely fastened, and it makes no difference which way they are mounted up.

*Figure 4 - Mounting Brackets:*

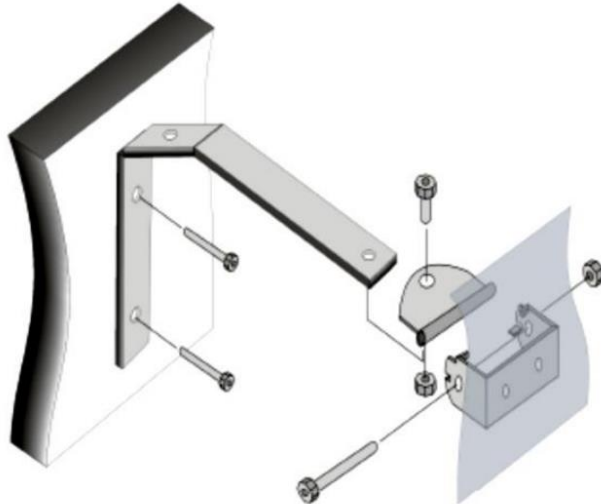

### 2.4 Angling the infrared heaters

The infrared heaters should be centred on the horse's body on either side and angled so they are pointing at the midline of the body or slightly above (i.e., a line running between the shoulders and flanks). If the subjects are of differing sizes, the optimal angle will be an average of the midlines.

*Figure 5 - Where the infrared Heaters should be pointing:*

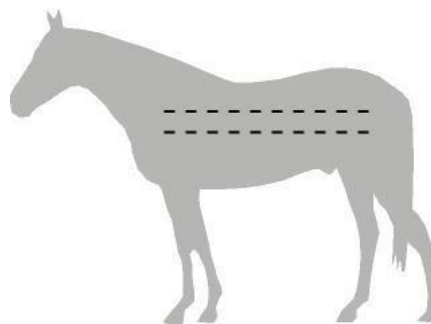

### 3.0 Wiring

Each infrared heater has a 3-core flexible cable exiting the rear of the heater. The two heaters joined either side of the horse should be wired together in parallel in a nearby junction box. This cannot be installed above the heater; only beside or below it. The junction box should have a rating of IP65 or above.

*Figure 6 - Cable routing to junction box:*

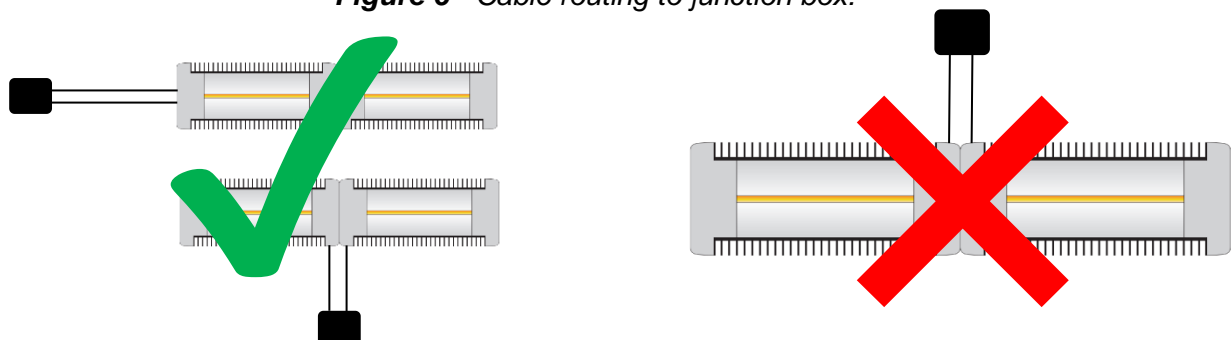

**3.1 Wiring Diagram**

The BH4C Solarium runs at 220 – 240Vac AC single phase. The maximum load of the two pairs of heaters combined is 6kW 240Vac, which will require a 6kW rated supply and earth. The supply first goes to the push button timer controller, then out into the CC3 variable controller. From here, two outgoing cables will supply two separate junction boxes which terminate both pairs of heaters. (cable and junction boxes not supplied)

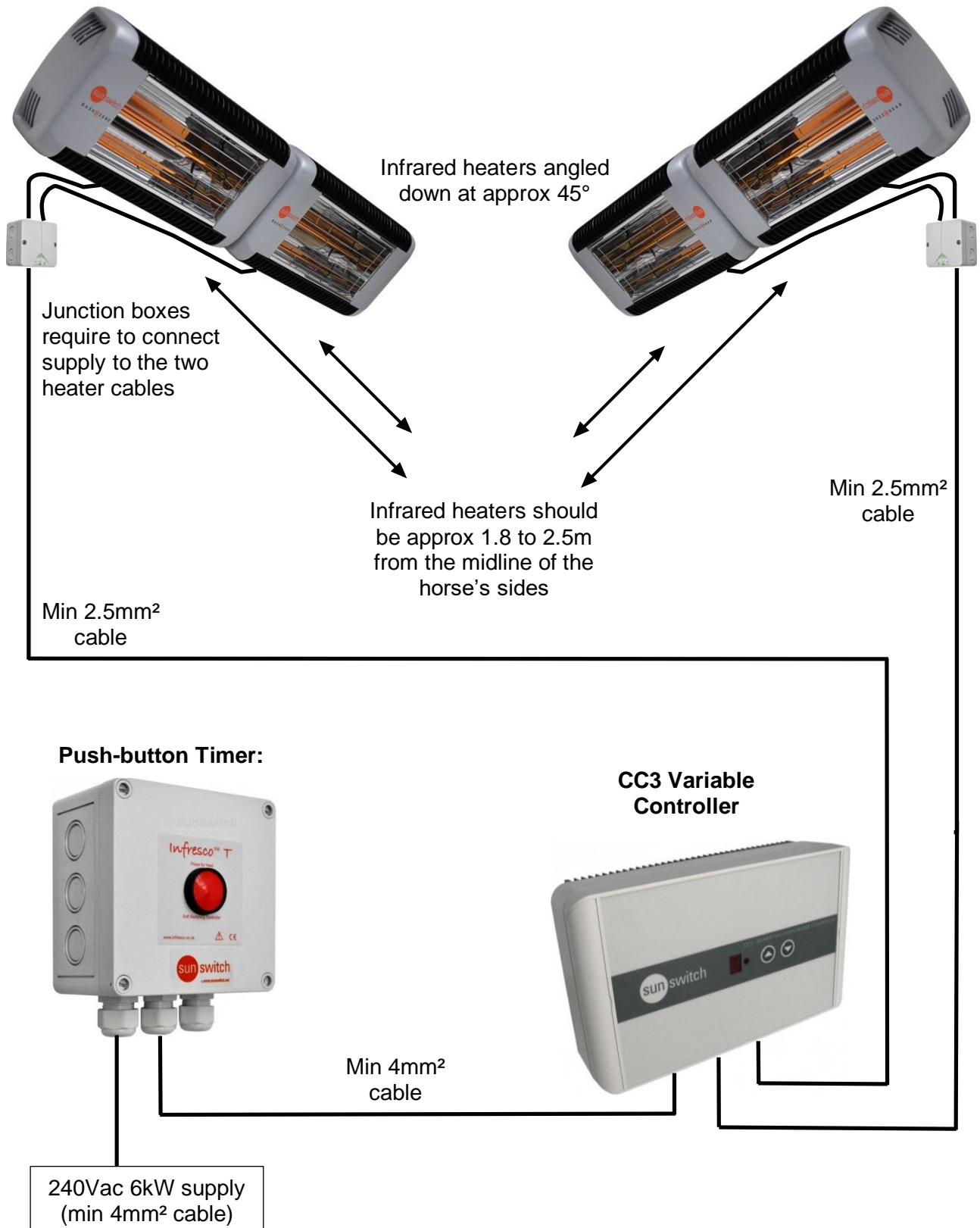

## 4.0 BH4C Technical Specifications

Individual heater rating	1.5kW IPX5
Push-button timer rating	6kW (IP65)
Variable controller rating	6kW (IP65)
Combined maximum load	6kW (4x 1.5kW heaters)
Supply voltage	220 - 240Vac 50 to 60 Hz
Wiring	3-core 1mm <sup>2</sup> cables (pre-wired)
Enclosure	Mild steel powder coated



This product must be disposed of responsibly at the end of its operating life. Please take to a waste collection Centre for electrical or electronic equipment

### Warranty

This product is covered by a 2-year warranty covering defective materials and manufacture. This does not affect your statutory rights.

*Specifications may change without notice. No liability can be accepted for any errors or omissions, or for any loss or injury arising from the incorrect installation, use or disposal of this product.*

### BaskZone® - The Equine brand of SunSwitch®

Telephone +44(0)1424 533 215

[www.baskzone.com](http://www.baskzone.com)